

15 L 16 Lp+

132 – 151 kNm 8 – 10,0 m 3,45 – 4,0 m 3,8 – 5 m 2.205 – 2.490 kg 420° 25 kNm 260 – 300 bar 80 l/min ~ 40 kW 65 l/min ~ 66 kW 150 l/min ~ 76 kW

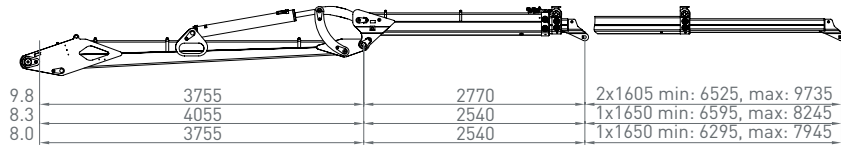
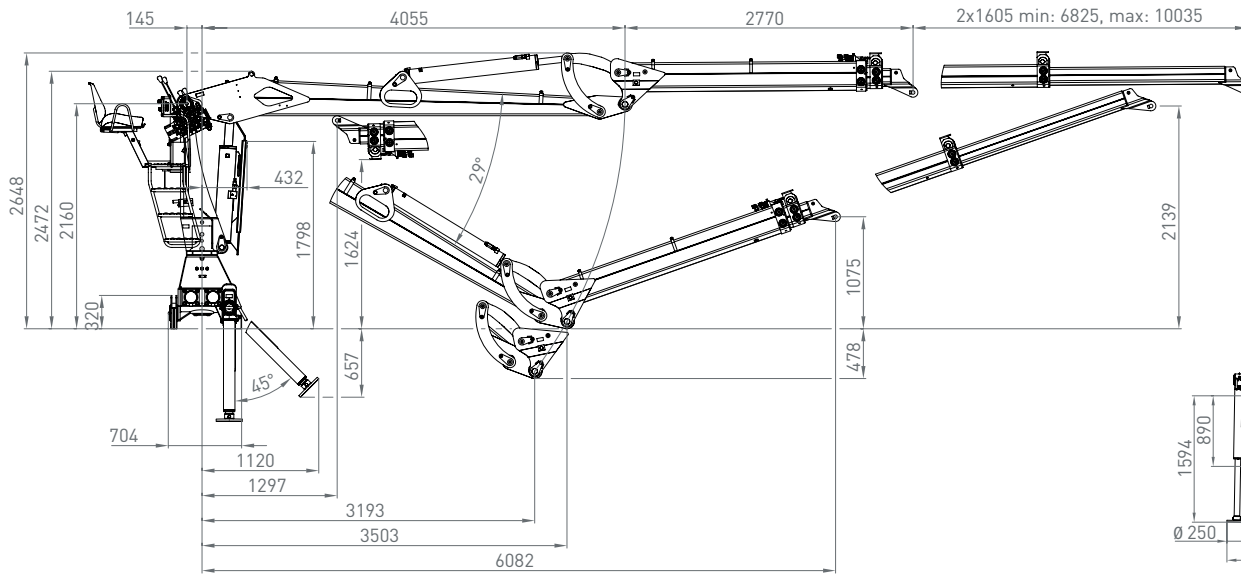

	4m	5m	6m	7m	8m	9m	
15L10.00	3250	2675	2225	1900	1640	1435	kg
16Lp+10.00	3600	2960	2460	2100	1810	1585	kg
15L9.80	3260	2685	2230	1910	1650	1440	kg
16Lp+9.80	3610	2970	2465	2110	1820	1590	kg
15L8.30	3330	2755	2300	1965	1705	-	kg
16Lp+8.30	3690	3050	2545	2170	1885	-	kg
15L8.00	3345	2775	2315	1980	-	-	kg
16Lp+8.00	3710	3070	2560	2190	-	-	kg

180° Hochklappung 180° of lifting up

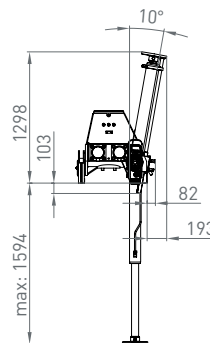

Rücksitz 01 Back seat 01

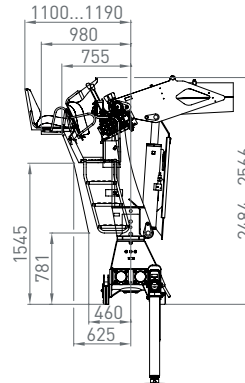

Rücksitz 02 Back seat 02

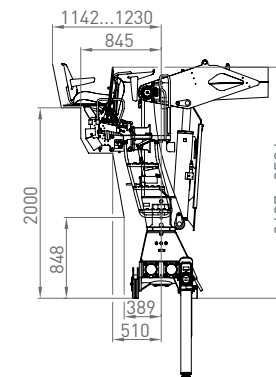

Seitensitz 02 universal rechts & links Side seat 02 universal right & left

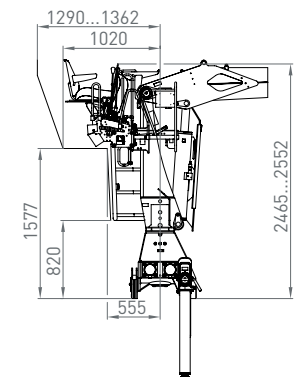

Sockel schmal Crane base small

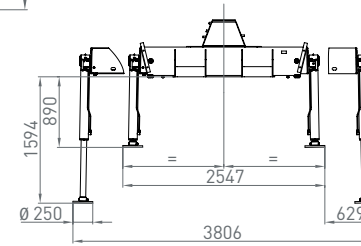

Sockel breit Crane base wide

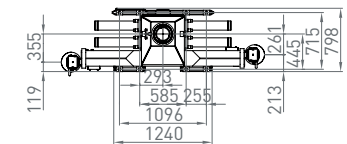
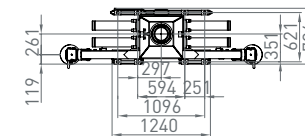
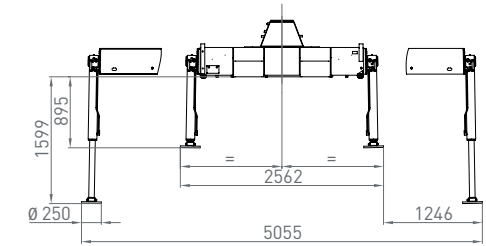

10,0

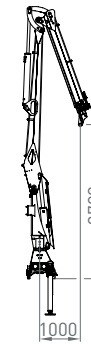

9,8

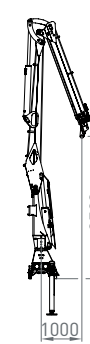

8,3



8,0

